

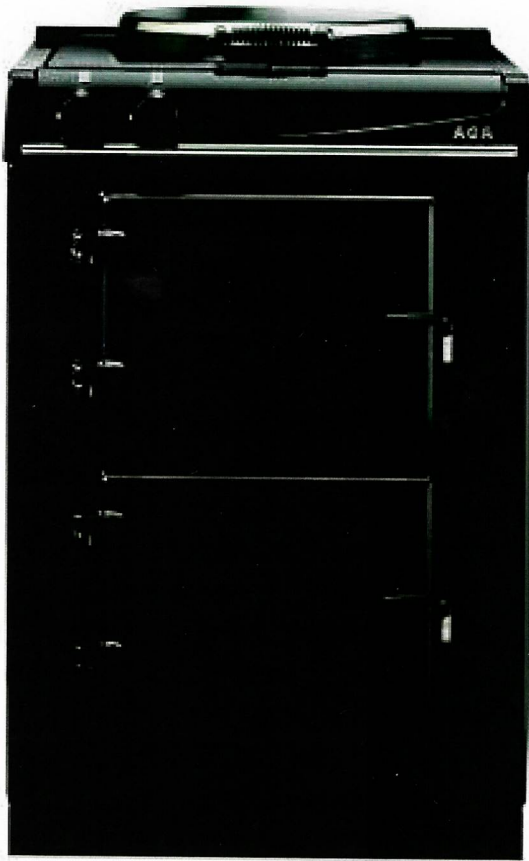

AGA CITY60 (CONTEMPORARY)

AGA CITY60 (TRADITIONAL)



AGA CITY60 CONTEMPORARY

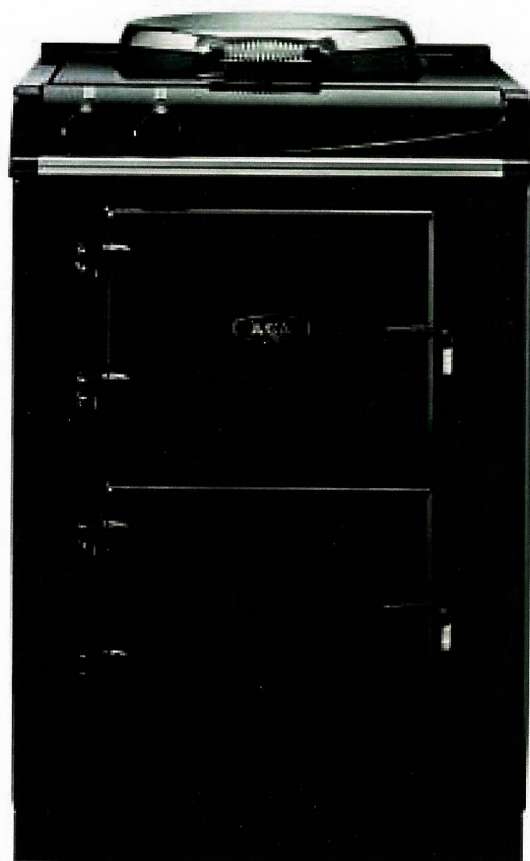

AGA CITY60 TRADITIONAL

Users Guide

REMEMBER: when replacing a part on this appliance, use only spare parts that you can be assured conform to the safety and performance specification that we require. Do not use reconditioned or copy parts that have not been clearly authorised by AGA.

PLEASE READ THESE INSTRUCTIONS BEFORE USING THIS APPLIANCE.

My AGA Details

AGA City60 (Contemporary) / City60 (Traditional)

Serial No _____

AGA Service No _____

Date of Installation _____

Contents

Warnings	4
Introduction	5
A Brief Description - AGA City60	6
Equipment Supplied with your AGA City60	7 - 8
How to use your AGA City60	9
Cooker Hoods and Oven Venting	10
General Advice	10
Using the Zones of the AGA City60	11
The Hotplate	11
Hotplate Control	11
The Boiling Plate Setting	11
The Simmering Plate Setting	11
The Resting Plates	12
The Ovens	12
The Roasting Oven Setting	13
The Baking Oven Setting	14
The Simmering Oven	15
The Simmering Oven - User Guidance	15
Quick Guide - Oven Usage	16
Fitting of Oven Shelves	17
Removal of Oven Shelves	17
Caring and Cleaning	18
Enamelled Cast Iron	18
Enamelled Cookware	18
Cast Iron Ovens and Hotplate	18
Lids and Oven Door/Lid Linings	18
Servicing and Warranty	19
Serial Number	19
Health and Safety	19

Warnings

WARNING: The appliance and its accessible parts become hot during use. Care should be taken to avoid touching heating elements. Children less than 8 years of age shall be kept away unless continuously supervised.

- The appliance can be used by children aged from 8 years and above and persons with reduced physical, sensory or mental capabilities or lack of experience and knowledge if they have been given supervision or instruction concerning use of the appliance in a safe way and understand the hazards involved. Children shall not play with the appliance. Cleaning and user maintenance shall not be made by children without supervision.

WARNING: Unattended cooking on a hob with fat or oil can be dangerous and may result in fire. **NEVER** try to extinguish a fire with water, but switch off the appliance and then cover flame e.g. with a lid or fire blanket.

WARNING: Danger of fire: Do not store items on the cooking surfaces.

WARNING: Accessible parts may become hot during use. Young children should be kept away.

Introduction

Your new AGA City60 gives you everything you love about the classic AGA cooker, but with the added convenience of the ability to turn each cooking zone on and off, as and when you want it.

Made in the heart of Shropshire, your AGA cooker like the generations of cookers before it, has been manufactured from cast iron at the Coalbrookdale Foundry. Traditional iron-making skills combined with industrial strength elements enable the ovens and hotplate to heat up rapidly, so you can have them all on, or just one on, depending on the time of day or the size of your army.

The cooking excellence of the AGA cooker has been famous since its inception in the 1920's, and is renowned due to the indirect radiant heat that its cast iron emits rather than just air temperature. And, if you haven't found out already, you'll soon discover that food that is cooked this way retains its natural flavour and succulence, and simply just tastes just better.

So grab a cup of tea, have a read, and prepare to dig into some of the tastiest dishes you're ever likely to make.

A Brief Description - AGA City60

Simmering Plate and Boiling Plate

Top Plate and Resting Area

Top Oven (Roasting Oven and Baking Oven setting)

Simmering Oven

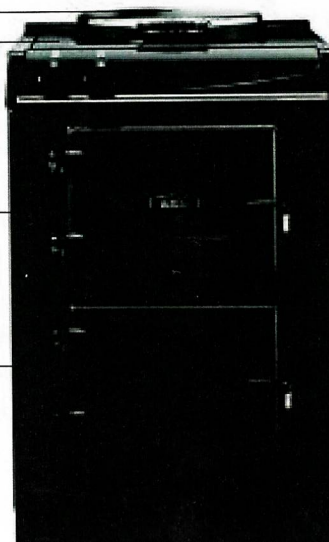

See page 9 for hotplate, oven symbols and brief description.

Hotplate

The hotplate has two different heat settings, the boiling plate setting being the hottest of the two, and the simmering plate setting at a lower heat.

Boiling Plate Setting

The boiling plate setting is used for making toast, boiling a kettle, stir-frying and cooking at a higher heat.

Simmering Plate Setting

The simmering plate setting is for slower cooking, such as sauces, simmering pans and can also be used to cook directly on for toasted sandwiches, drop scones, non-fat fried eggs and quesadillas.

Top Oven (Roasting Oven Setting)

The hottest oven setting for high temperature cooking; pastries, breads, roasting of meat, vegetables and poultry, grilling at the top of the oven and frying on the floor grid on the base of the oven. The ovens are vented into the room, so some cooking smells will be present.

Top Oven (Baking Oven Setting)

A moderate oven setting for cooking cakes and biscuits, baking fish, lasagne or shepherd's pie, plus roasting meat and poultry at a medium heat. Cooking sweet and savoury together is no problem as the flavours do not mix.

Simmering Oven

Long, slow cooking in the simmering oven develops flavours and makes the toughest meat tender. It's large capacity means several pans can be stacked here; soup, casserole, steamed rice, steamed carrots and poached pears all cooking simultaneously, without any danger of burning.

The appliance is not intended for use by young children or infirm persons without supervision.

Young children should be supervised to ensure that they do not play with the appliance.



WARNING : Accessible parts will become hot when in use. To avoid burns and scalds children should be kept away.

Equipment supplied with your AGA City60



Large Size Roasting Tin with Grill Rack

This is designed to slide onto the oven runners without the need for it to sit on an oven grid shelf. The roasting tin can be used with the grill rack, in its high position, for grilling at the top of the roasting oven. It can be used for roasting meat, or poultry with or without the grill rack. Large quantities of roast potatoes can be cooked in this tin. The roasting tin can also be employed for making large traybakes or cakes. The grill rack is useful on its own as a cake cooling rack. Can be used in any oven but not recommended for hotplate use.



Half Size Roasting Tin and Grill Rack

This tin can be slid onto the oven runners width-ways or can sit on an oven grid shelf. The half size roasting tin can be used with the grill rack, in its high position, for grilling at the top of the roasting oven. It can be used for roasting smaller joints of meat, or poultry with or without the grill rack. Roast potatoes can be cooked in this tin. The roasting tin can also be employed for making traybakes or cakes. The grill rack is useful on its own as a cake cooling rack. Can be used in any oven but not recommended for hotplate use.



2 Floor Grids

These grids are used on the base of the ovens, to protect food from the heat of the base element.



2 Oven Grid Shelves

These are for inserting in each oven to provide a surface for dishes and tins which do not fit directly onto the oven runners. They can be used in any oven, as required. See page 17 on how to locate the oven shelves correctly.

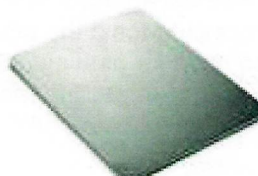

1 Cold Plain Shelf

This has two uses one as a large baking sheet for scones, biscuits, pastry items and meringues and the other use as a heat deflector to cut off the top heat if food is overbrowning before it is cooked through.

DO NOT STORE IN THE OVENS WHEN NOT IN USE.



Toaster

This is for toasting bread on the boiling plate. AGA toast is renowned for its excellence, crisp on the outside and soft in the centre. Take thick slices of bread and place in the AGA toaster - if the bread is very moist or very fresh, heat the toaster beforehand to prevent sticking - lift the boiling plate insulated cover and place the toaster direct onto the plate with the handle at an angle from the handle of the cover.

Close the cover and wait for the bread to toast one side - this will take 1-2 minutes dependent upon the variety of bread - open the cover and turn the toaster over and repeat the process to toast the other side. The toaster can also be used for heating pitta bread, toasting teacakes and as a cake cooling rack.



AGA Utensils and Accessories

To get the very best performance from your cooker we recommend AGA saucepans with the thick tri-core bases and stacking lids so that the maximum use of oven space is made and an AGA kettle for boiling water. AGA Accessories can be viewed at your AGA Specialist or online at www.agacookshop.co.uk



Wire Brush

This is for cleaning the raw cast iron surfaces, keeping them clear of crumbs and burnt on debris – which would otherwise affect the boiling performance of pans and the kettle. Use on the hotplate and the ovens. Take care not to touch the enamel surfaces as the wire brush will scratch the finish.

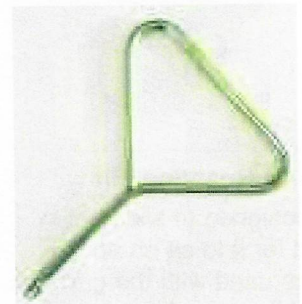

Resting plate lifting tool

To aid removal of the cast iron resting plates for cleaning.

Getting to know your AGA

If you have not already seen a demonstration, ask your AGA Specialist for details. A demonstration will show you how to get the best from your new AGA and will give you hints and tips. You will also see a selection of AGA utensils and accessories being used. Please take a look at www.agaliving.com.

How To Use Your AGA City60

Getting started

When switching on the AGA cooker for the first few times, there are two things you may notice, neither of which should cause concern.

The AGA cooker will emit an odour for a short while, this is simply due to the protective oil we put on the hotplate and ovens burning off. Due to the newness in the first couple of hours, it is advisable to open the kitchen window while this takes place.

Condensation may occur on the top and front plate whilst the AGA cooker is heating up, caused by the insulation lagging and starch binder on the element insulation drying out. The condensation should be wiped away as soon as possible to prevent staining the enamel.

Your AGA City60 has the external appearance of a classic AGA heat storage enamelled cast iron cooker. However, it's flexibility is almost unbounded because in place of a single heat source each cooking zone has its own electrically heated cast iron element (s). The separation of cooking zones, allows a choice of control. You are able to select only the zones that you want, or need, to use.

Hotplate



OFF



Boiling Setting



Simmering Setting

Ovens



OFF



Top Oven - Baking Setting ON
Simmering Oven OFF



Top Oven - Baking Setting ON
Simmering Oven ON



Top Oven - OFF
Simmering Oven ON



Top Oven - Roasting Setting ON
Simmering Oven ON



Top Oven - Roasting Setting ON
Simmering Oven OFF

Cooker Hoods and Oven Venting

It is recommended that this AGA is fitted with a cooker hood above it. The AGA venting system is located on top of the AGA and is designed for venting the moisture from the ovens. The cooker hood should be positioned not less than the minimum height as recommended by the manufacturer, from the top of the AGA.

The AGA City60 ovens are manufactured from cast iron, over a period of time they will become individually seasoned.

However, the ovens will rust if high moisture content foods are not covered (especially in the simmering oven) or spillages are not cleaned up.

It is also not advisable to leave a full or partially filled saucepan/utensils with high moisture content food in the ovens when they are not in use.

To season the ovens a light vegetable oil is ideal (corn oil is best), spray oil is recommended. Any stubborn stains can be removed with the wire brush supplied.

Please refer to Page 18, for Cleaning of Ovens.

General Advice

Food **SHOULD NOT** be placed into any oven until it is up to normal operating heat.

The oven doors should not be left open for long periods of time during cooking and heating up.

Store the cold plain shelf outside the cooker. Use it cold in the roasting oven to deflect heat from the top of the oven, creating a more moderate oven temperature underneath. It can also be used as a baking sheet.

Warm up times

As the AGA works on the principle of storing heat, time is required to gather that heat from the electric elements to saturate the castings. **We recommend to allow an hour heat up time.** The optional programmer is a great asset as it can be set to get the top oven to its working heat, ready for you to cook when you walk through the door.

The principle of heat storage means that the ovens and hotplate are at a pre-set heat, the cooking areas are named after their function rather than temperatures.

Using the Zones of the AGA City60

The different zones of the AGA City60 cooker are described individually, in the following pages.

The traditional AGA heat storage cooker is famous for the gentle warmth it emits, with the AGA City60 you will get warmth only when the cooker is on or warmth to a lesser degree when only parts of it are on.

The Hotplate

The cast iron hotplate is operated manually and is machined flat to give the best all-over contact with the AGA saucepans, grill pan, frying pan and kettle.

Cleaning details can be found on Page 18.



The boiling plate setting is the hottest with the simmering plate setting being cooler. It has electric elements embedded into the cast iron which heat up in approximately 11 and 8 minutes respectively. The hotplate can be used completely independently from the ovens.

The whole hotplate area can be used for cooking and several pans can be accommodated on the plate at any one time. The hotplate is set very slightly above the top plate to minimise scratching as the pans are pulled to one side to simmer.

The chrome insulated cover is brought down over the hotplate when it is heating up or not in use. When the hotplate is 'ON' the insulated cover will be warm. We **strongly advise** not to put anything such as kettles, saucepans or baking tins directly onto the insulated cover because it will show any scratches - invest in a chef's pad to protect the surface if the cover is to be used as a resting place!

Keep the hotplate clear of any burnt on food or crumbs by brushing with the wire brush, supplied with your AGA. Cleaning details can be found on Page 18.

Hotplate Control

To operate the boiling plate setting turn the control knob to the  position and similarly to the  for the simmer plate setting.

The Boiling Plate Setting

The hottest setting, the boiling plate setting is used for boiling, grilling, stir-frying, making toast - indeed anything that requires a high heat. Green vegetables keep their colour when boiled quickly here, or use a steamer over the saucepans to cook more than one vegetable at once.

When stir-frying or cooking anything that is inclined to splash we would recommend using an AGA Splash Shield which will protect the insulated cover from splatter, making cleaning a doddle! Just wash the Splash Shield in hot soapy water or place in a dishwasher between two dinner plates.

Please be advised the boiling plate setting is too hot to cook food directly on it.

The Simmering Plate Setting

The simmering plate setting is the cooler of the two settings and so is used for recipes that require a lower heat such as, making sauces, scrambling eggs, heating milk, slow frying, simmering soups and root vegetables. In addition, it can be used to cook on directly as a form of griddle - invaluable for toasted sandwiches, quesadillas, drop scones, searing scallops and even a non-fat fried egg! Slow cooked toast can be made on the simmering plate setting, no need to use the AGA toaster here.

The Resting Plates

The resting plates are useful when you wish to move a pan off boil or to a lower temperature.

Take care when removing and replacing the cast iron resting plates, as they are heavy. Ensure they are cold before removing.

Removing resting plates

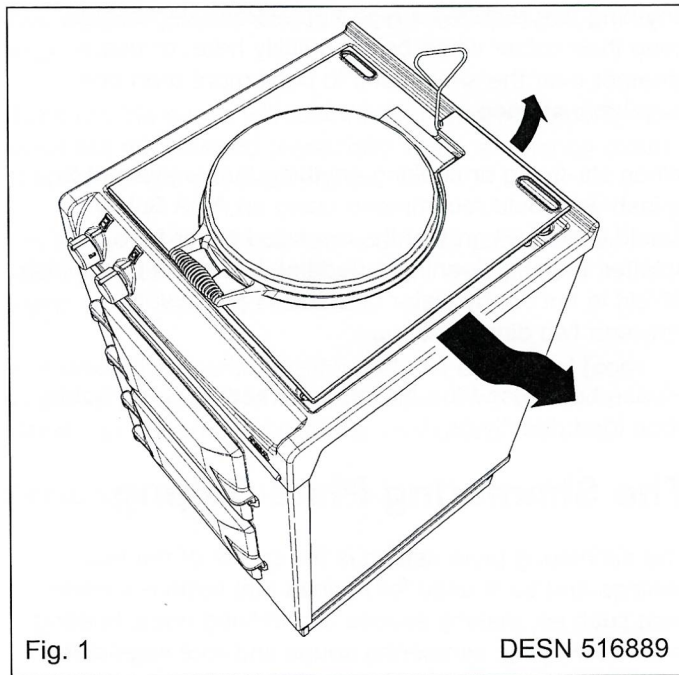

Insert lifting tool in recess at rear of resting plate. Lift up at rear, the slide out carefully from the side, See Fig. 1.

Replacement of resting plates



Replace resting plates carefully, as shown in Fig. 2.

The Ovens

Your AGA City60 has two ovens which are pre-set at a different heat, just like the traditional AGA heat storage cooker. The top oven has two temperature settings one for the roasting and one for baking.

Top Oven

The Roasting Oven Setting

for high temperature cooking

The Baking Oven Setting

for moderate temperature cooking

The Simmering Oven

for long, slow cooking.

DO NOT OPERATE THIS APPLIANCE WITH THE DOORS OPEN, SINCE THIS CAN CAUSE A LOCK-OUT.

Each oven has the same capacity, (able to fit a 13kg (28lb) turkey) and the traditional AGA heat-storage cooker techniques can be used, such as stacking saucepans in the simmering oven. This enables the steaming of root vegetables, rice, steamed pudding, casserole, poaching fruit all in the same oven leaving the hotplate free.

You can have one or two ovens on at their pre-set heat.

The ovens are made from cast iron, which cooks by a radiant heat and this is the secret of the cooking excellence for which the AGA cooker is renowned. An indirect radiant heat does not dry food out, so it retains its natural moisture and flavour.

The Roasting Oven Setting



The roasting oven setting is indirectly heated by two elements, one in the base of the oven and the other in the roof. These elements heat the air and the cast iron within to provide cooking results consistent with the traditional AGA heat-storage cooker, with the flexibility of being able to turn the off when not in use.

The roasting oven setting can be used for 'grilling' at the top and 'shallow frying' on the oven floor.

When cooking on the base of the roasting oven, place the floor grid on the base before putting the food into the oven. This lifts the food away from the base element to ensure best cooking results are achieved.

The roasting oven setting is zoned in heat, meaning it is slightly hotter towards the top than the centre and the oven grid shelf set on the oven floor is slightly less hot than the centre.

The base of the oven can be used as another cooking surface, indeed it is often called a hidden hotplate use the floor grid for protection so food does not overbrown.

The beauty of the roasting oven setting is that any fat is burnt off when the oven is at full heat, just brush out occasionally to remove the carbon deposits.

The roasting oven setting is excellent for bread and pastries. Quiches in ceramic or pies in Pyrex dishes need not be baked blind as when they are in placed on the floor grid on the base of the oven the pastry cooks from underneath and the filling will set and brown from the all-round heat. As you are aware metal flat tins conduct heat quicker than ceramic may need less cooking time.

The specially designed roasting tins and bakeware slide directly onto the runners, so almost every available square centimetre of space can be used. Food can be protected by the use of the cold plain shelf or shielded by means of the large roasting tin which means you can cook food that requires different temperatures at the same time. If food is browning too quickly and you do not want to move it to another oven just slide the cold plain shelf over the food to reduce the top heat.

The Baking Oven Setting

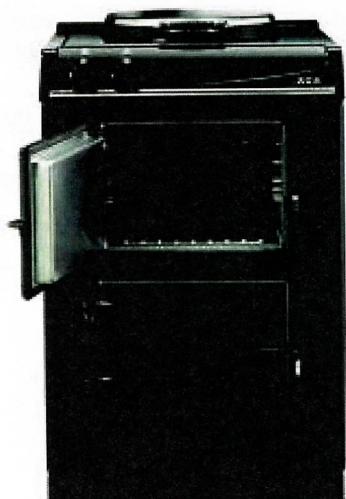

The oven is indirectly heated by two elements, one in the base of the oven and the other in the roof. These elements heat the air and the cast iron within to provide cooking results consistent with traditional AGA heat storage cookers, with the flexibility of being able to turn it off when not in use.

This setting is a moderate heat, so is ideal for cakes, biscuits, also anything that requires medium heat cooking such as fish pie, lasagne, soufflés, crumble and roulades. Meat and poultry can be cooked here indeed most things that can be cooked on the roasting oven setting can be cooked on the baking oven setting but for a longer time.

For the best results when cooking cakes do allow at least the one hour heat up time. Cook cakes together on one shelf. If two shelves are used interchange the food to achieve even colouration, as you would with any oven which is zoned heat.

As with the roasting oven setting, the specially designed roasting tins and bakeware slide directly onto the runners, so almost every available square centimetre of space can be used. Food can be protected by the use of the cold plain shelf or shielded by means of the large roasting tin, which means that you can cook food that requires different temperatures at the same time. If food is browning too quickly and you do not want to move it to another oven just slide the cold plain shelf over the food to reduce the heat.

NOTE: When baking it is always best to start from cold, otherwise if baking after using the roasting setting the oven will take a considerable amount of time to cool.

NOTE: Always remove the cold plain shelf and roasting tins on completion of cooking, if left in the oven it will affect the oven temperature.

The Simmering Oven



The simmering oven is indirectly heated by one element in the base of the oven.

This element heats the air and the cast iron within it to provide cooking results consistent with the traditional simmering oven of the traditional AGA heat-storage cooker, with the flexibility of being able to turn it off when not required.

The floor grid is used here to protect items placed on the base of the oven such as vegetables for steaming, keeping sauces warm or casseroles cooked for a long time. Always ensure this is in place, before putting food into the oven.

The simmering oven can be described as a continuation oven, it continues to cook food that has been brought up to heat elsewhere on the cooker with the exception of meringues which are dried out rather than 'cooked'.

The Simmering Oven

User Guidance

- Allow the oven to heat fully, the longer the oven is on the better, we recommend one hour.
- To get the very best performance, we recommend to use AGA cookware with thick bases and stacking lids.
- Do not place dishes directly on to the oven base. Always place onto either a shelf or the floor grid.
- Joints of meat and poultry should be brought up to heat ideally on the roasting oven setting for 30-45 minutes, then transferred to the simmering oven. (This method is unsuitable for stuffed meat and stuffed poultry).
- Make sure that pork and poultry reach an internal temperature of at least 75°C.
- Always bring soups, casseroles and liquids to the boil before putting in the simmering oven.
- Always thaw frozen food completely before cooking.
- Root vegetables will cook better if cut into small pieces.
- Adjust seasoning and thickenings at the end of the cooking time.
- Many dried pulses and beans for example, dried red kidney beans must be boiled for a minimum of 10 minutes, after soaking, and before inclusion in any dish.

Below is a quick guide to oven usage

AGA OVENS

ROASTING OVEN SETTING

- Grilling
- Scones
- Pastries
- Bread
- Yorkshire puddings
- Roasts
- Shallow frying

BAKING OVEN SETTING

- Cakes
- Biscuits
- Fish
- Shepherds pie, Cottage pie
- Lasagne
- Soufflés
- Shortbread

SIMMERING OVEN

- Casseroles
- Stock
- Milk puddings
- Meringues
- Rich fruit cake

OVEN TEMPERATURE

HIGH

- **Top** - grilling
- **2nd runner** - scones, small pastries, grilling
- **3rd runner** - bread rolls , Yorkshire pudding
- **4th runner** - roasts, poultry
- **Oven grid shelf on base of oven** - bread loaves, pies, roast vegetables
- **Floor grid on base of oven** - quiches, pies

MODERATE

- **Towards top** - whisked sponges, some biscuits, small cakes
- **Middle** - fish, soufflés, shepherd and cottage pie, lasagne
- **Oven grid shelf on base of oven** - Victoria sandwiches, shortbread, traybakes and cheesecake

LOW

For casseroles, stock, milk puddings and similar dishes bring to heat elsewhere on the AGA then transfer to the simmering oven (one exception is meringues). Rich fruit cakes can be cooked here for a, long time on the oven grid shelf placed on the base of the oven.

Fitting of Oven Shelves

When using the oven shelves, follow Figs. 3 - 6.

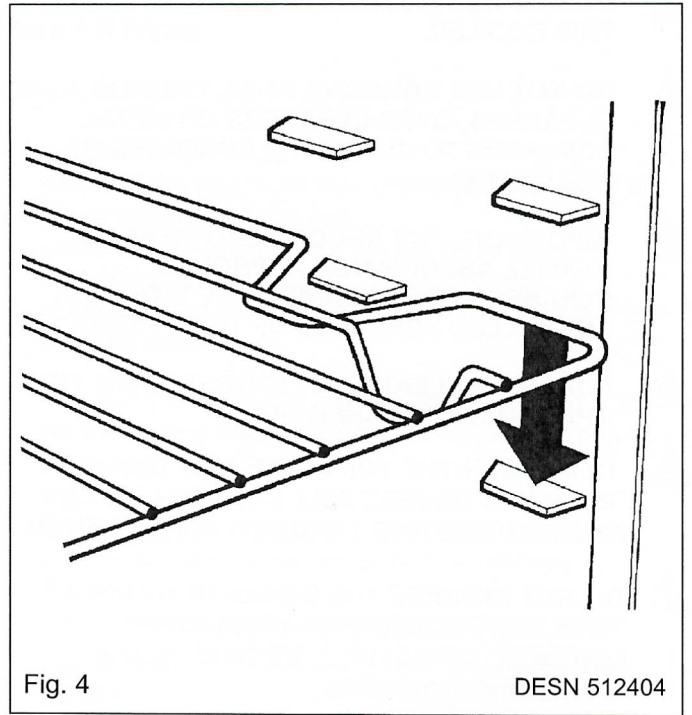
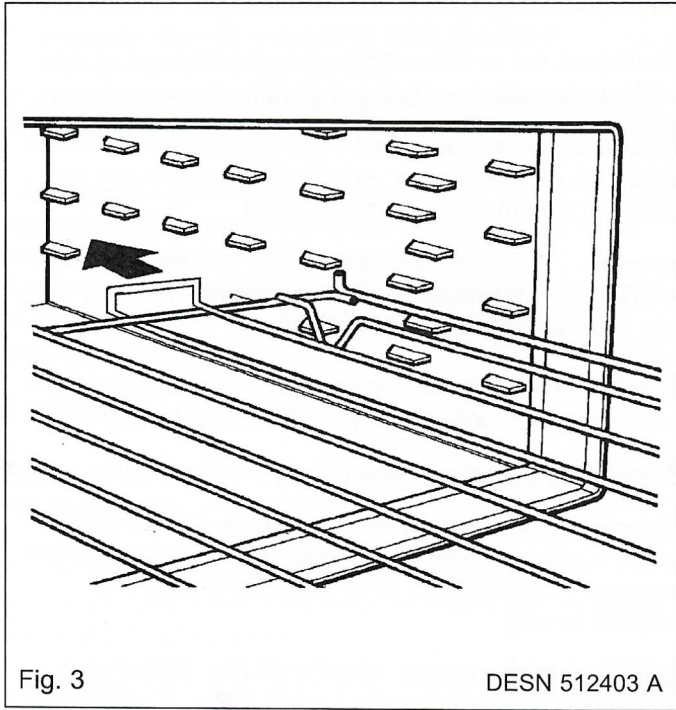



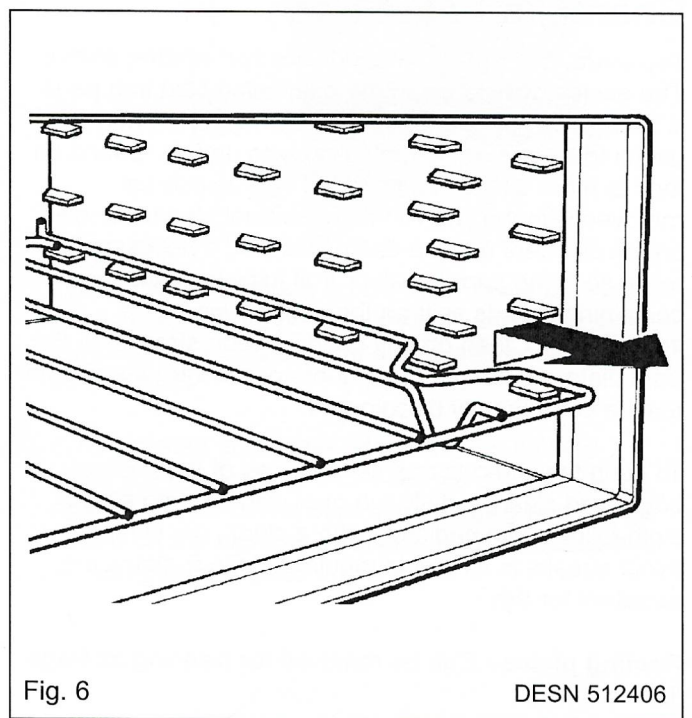
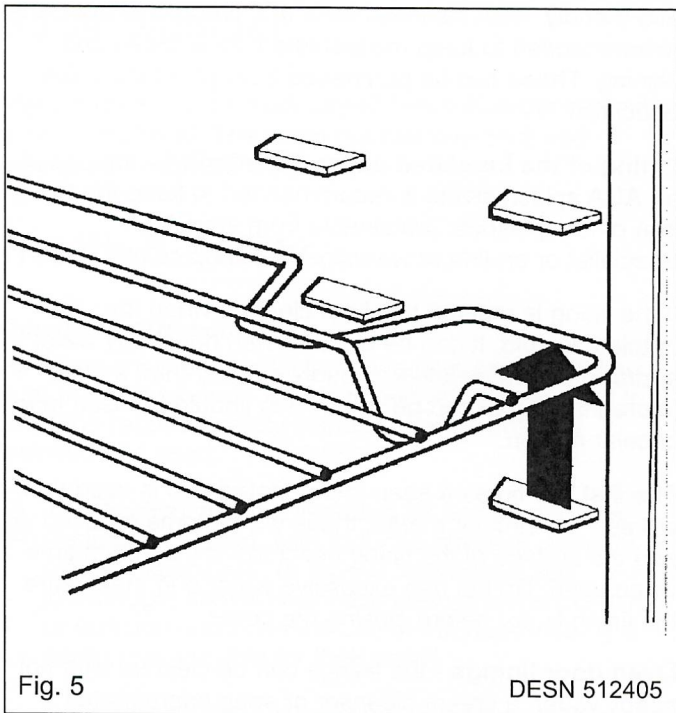



Removal of Oven Shelves



Caring and cleaning

REMEMBER: BE CAREFUL OF THE HOT APPLIANCE.

-  **DO NOT USE A STEAM CLEANER TO CLEAN THIS COOKER.**
-  **DO NOT USE ABRASIVE PADS, CAUSTIC CLEANERS, OVEN CLEANERS OR METAL SCRAPERS TO CLEAN THE SURFACES OF THE ENAMEL.**
-  **IMPORTANT - WE RECOMMEND VITREOUS ENAMEL ASSOCIATION APPROVED CLEANERS FOR CLEANING THE VITREOUS ENAMELLED SURFACES OF THIS PRODUCT.**
-  **FOR MOST CLEANING IT IS BEST WHEN THE APPLIANCE IS TURNED OFF.**
-  **REMEMBER THE TOP PLATE AND THE POLISHED COVERS WILL SCRATCH IF PANS OR UTENSILS ARE DRAGGED ACROSS THEM.**
-  **DO NOT IMMERSE THE DOORS IN WATER AS THEY ARE PACKED WITH INSULATING MATERIAL, WHICH WILL BE DAMAGED BY EXCESSIVE MOISTURE.**
-  **DO NOT PUT OVEN DOORS OR RESTING PLATES IN A DISHWASHER.**

Enamelled cast iron

Top plate, front plate, oven doors and resting plates -

The easiest way to clean the enamelled cast iron parts is to mop up spills as soon as they happen. It may be useful to keep a damp cloth handy to do this. Baked on food is more difficult to clean but can usually be removed with the AGA vitreous enamel cleaner or mild cream cleaners using a damp cloth, or, if necessary a nylon scouring pad. If milk or fruit juice or anything containing acid, is spilt on the cooker, wipe it up immediately. Clean off any condensation streaks on the front plate around the oven doors or the vitreous enamel maybe permanently discoloured.

To keep the vitreous enamel surfaces of the cooker bright and clean, a daily rub over with a damp soapy cloth followed immediately with a clean, dry cloth to avoid streaks is all that is required. AGA E-cloths are excellent for this.

Resting plates - Can be removed for cleaning as Page 12.

Enamelled cookware

Enamelled roasting tins - supplied with the AGA City60 should be cleaned in hot soapy water, soaking if necessary. A nylon scouring pad can also be used. They may also be cleaned in the dishwasher, but with constant use, the enamelled finish will become dull in appearance.

Cast iron ovens and hotplate

Ovens - are made from cast iron and keep themselves clean. They are very durable, but will rust if surface moisture is left on them. Remember to always switch the ovens on, to dry them out after cleaning.

Heating up the ovens periodically will help burn off any cooking deposits to aid cleaning within the ovens.

To season the ovens, a light vegetable spray oil (corn oil is best) is recommended. Any stubborn stains can be removed with the wire brush supplied.

Hotplate - is made from cast iron, and is easy to care for. Regular maintenance will ensure long-life. They will rust if surface moisture is left on them

Should the hotplate become soiled, use a sponge, cloth, scouring pad or wire brush to remove burnt-on spills.

Rinse off detergents or cleaning agents thoroughly.

Remember to switch on the hotplate for a few minutes to dry it after cleaning. Every now and then, apply a thin coating of vegetable oil (corn oil is best) when the hotplate is cold.

Lids and oven door/lids linings

The top of the insulated cover (lid) - this is chrome or stainless steel and can be kept clean by wiping over with a damp cloth and polished up - the AGA E-cloths are excellent for this purpose as they are lint-free and eco-friendly. AGA stainless steel and chrome cleaner are recommended to keep the insulated cover clean and shining. These can be purchased from your local AGA Specialist.

Lining of the insulated cover (lid interior) - the use of an AGA splash shield is recommended to keep the lining free of fat splashes, (obtainable from your AGA Specialist or on-line at www.agacookshop.co.uk).

If the lining is marked it is best cleaned when the hotplate is cold. It can be cleaned with hot soapy water and/or a cream cleanser. If badly marked then a soap impregnated pad can be used - this should be used in a circular motion.

The first few times a soap impregnated pad is used you will see the circular marks, these will become reduced and the surface of the lining becomes shinier each time when used. Do not use excessive water and make sure the lining is dry before closing the cover.

Oven door linings - the linings can be cleaned with hot soapy water, a cream cleanser or soap impregnated pad. To deep clean the lining place a towel on the work surface and carefully lift off the oven door (doors are heavy) and place it enamel side down on the towel padding. Clean with a soap impregnated pad to remove stubborn marks. Dry off before replacing on their hinges.



WARNING : Accessible parts will become hot when in use. To avoid burns and scalds children should be kept away.

Servicing & Warranty

- In the event of your appliance requiring maintenance, please contact AGA Service or your AGA Specialist.
- Your cooker must only be serviced by a qualified engineer, from an authorised AGA Specialist.
- Do not alter or modify the cooker.
- Only the spares specified by the manufacturer, are to be fitted.

For continued efficient and safe operation of this appliance, it is important that servicing is carried out at regular intervals as recommended by your AGA Specialist. The cooker should be turned OFF in advance of the service so that the appliance will have cooled down sufficiently.

A HOT APPLIANCE CANNOT BE SERVICED.

Service intervals to maintain the appliance warranty are as follows:

An interim service is due at two and half years (30 months) to check and change consumable items, and to undertake a safety check.

A full service is due at the end of year five (60 months). The appliance warranty does not cover Commercial use (see separate Warranty book provided for further details).

Serial Number

Make a note of your AGA City60 Serial Number when it is being installed. The serial number can be found behind the magnetic plinth cover.

Health & Safety

Consumer Protection

As a responsible manufacturer, we take care to make sure that our products are designed and constructed to meet the required safety standards when properly installed and used.

 This appliance is not intended for use by persons (including children) with reduced physical, sensory or mental capabilities, or lack of experience and knowledge, unless they have been given supervision or instruction concerning use of the appliance by a person responsible for their safety.

 Children should be supervised to ensure that they do not play with the appliance.

IMPORTANT NOTICE: PLEASE READ THE ACCOMPANYING WARRANTY

Any alteration that is not approved by AGA could invalidate the approval of the appliance, operation of the warranty and could also affect your statutory rights.

APPLIANCE

 **YOUNG CHILDREN SHOULD BE KEPT AWAY FROM THE APPLIANCE AS SURFACES CAN BECOME HOT TO TOUCH.**

Deep Fat Frying

IMPORTANT

- Use a deep pan.
- Never fill the pan more than one-third full of fat or oil.
- Never use a lid on the pan.
- Important: Oil is a fire risk, do not leave pans containing oil unattended.
- In the event of a fire, cover the pan with a lid and turn OFF the appliance.

Smother the flames on the hob preferably with a fire blanket, rather than attempting to remove the pan to the outside.

Burns and injuries are caused almost invariably by picking up the burning pan to carry it outside.

- **Do not hang clothes on the the AGA hand-rail.**

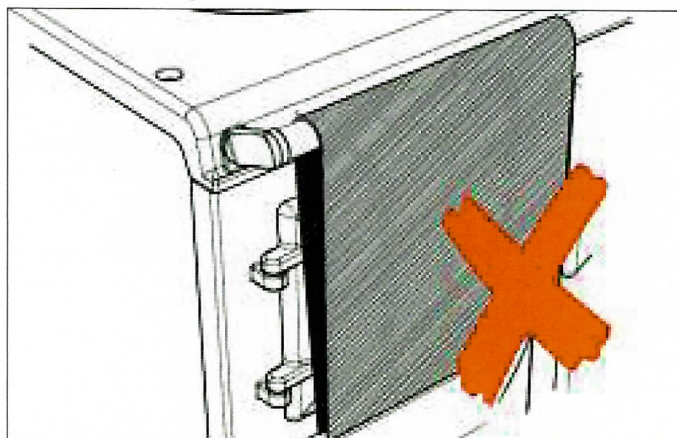

 When the oven (s) are on **DO NOT** leave any oven door open for long periods, this will affect the temperature of the oven and may allow controls to become hot.

 A little smoke and some odour may be emitted when the appliance is first switched on. This is normal and harmless from oven lagging and starch binder on the element insulation and will cease after a short period of use.



WARNING : Accessible parts will become hot when in use. To avoid burns and scalds children should be kept away.

**For further advice or information contact
your local AGA Specialist**

With AGA Rangemaster's policy of continuous product improvement, the Company reserves the right to change specifications and make modifications to the appliance described and illustrated at any time.



Manufactured by
AGA Rangemaster
Station Road
Ketley Telford
Shropshire TF1 5AQ
England

www.agaliving.com
www.agacookshop.co.uk