



from AGA

Installation Instructions for Rayburn 216SFW Solid Fuel and Wood Burning Cooker



Consumer Protection

As responsible manufacturers we take care to make sure that our products are designed and constructed to meet the required safety standards when properly installed and used.

IMPORTANT NOTICE: PLEASE READ THE ACCOMPANYING WARRANTY.

Any alteration that is not approved by AGA, could invalidate the approval of the appliance, the warranty and could also infringe the current issue of the statutory requirements.

All local regulations including those referring to national and European standards need to be complied with when installing this appliance.

Control of Substances - Health & Safety Important

This appliance may contain of the materials that are indicated below. It is the Users/Installers responsibility to ensure that the necessary personal protective clothing is worn when handling, where applicable,

the pertinent parts that contain any of the listed materials that could be interpreted as being injurious to health and safety, see below for information.

Firebricks, Fuel beds, Artificial Fuels- when handling use disposable gloves.

Fire Cement - when handling use disposable gloves.

Glues and Sealants - exercise caution - if these are still in liquid form use face mask and disposable gloves.

Glass Yarn, Mineral Wool, Insulation Pads, Ceramic Fibre, Kerosene Oil - may be harmful if inhaled, may be irritating to skin, eyes, nose and throat. When handling avoid inhaling and contact with skin or eyes. Use disposable gloves, face-masks and eye protection. After handling wash hands and other exposed parts. When disposing of the product, reduce dust with water spray, ensure that parts are securely wrapped.

INTRODUCTION

REMEMBER: when replacing a part on this appliance, use only spare parts that you can be assured conform to the safety and performance that we require. Do not use reconditioned or copy parts that have not been clearly authorised by AGA.

The Rayburn 216SFW is intended to supply heating for:-

- (a) Cooking and domestic hot water.
- (b) Cooking, domestic hot water and central heating.

The cooker meets the requirements of BS EN 12815 : 2001 and A1 : 2014. and is fully approved under the HETAS Ltd Approval Scheme.

Air for combustion within the firebox and the rate of burning is determined by the manually operated spinwheel control on the ashpit door.

WARNING

THE ASHPIT AND FIREBOX DOORS MUST BE LOCKED CLOSED AT ALL TIMES DURING NORMAL USE, EXCEPT WHEN LIGHTING OR RE-FUELLING

Weight of appliance - 305 Kgs

The mean flue gas temperature directly downstream of the flue spigot at nominal heat output is 295°C.

This appliance has been tested using Ancit manufactured smokeless fuel and wood logs.

The minimum clearance to combustible materials is 150mm.

Domestic Hot Water (solid fuel or wood)

When fitted for domestic hot water, the cooker will, with normal usage in 24 hours continual burning with solid fuel or wood provide two or three baths at intervals and hot water for normal household requirements. The following conditions must be fulfilled:-

1. Use only an indirect hot water storage cylinder of the double feed type, not less than 190 litres actual capacity, and to BS: 1566: Part 1 DF: Type 10.
2. The cylinder to be effectively lagged, and fixed vertically.
3. The cylinder should be as near to the cooker as possible. In no case may 1in B.S.P. or 28mm copper flow and return pipes exceed 10m each in length.
4. 1in B.S.P. or 28mm flow and return pipes exceeding 5m each in length must be lagged.
5. The draw-off pipe to the taps must be dead-leg connection from the expansion pipe.

NOMINAL HEAT OUTPUT : 8.1 - 8.4 kW	TOTAL SPACE HEATING OUTPUT : 2.5 - 3.6 kW
TOTAL WATER HEATING OUTPUT : 4.8 - 5.6 kW	
MINIMUM DISTANCE TO COMBUSTIBLE MATERIAL : 150mm	
APPLIANCE EFFICIENCY : 72.8 - 78.4%	
CO CONCENTRATION AT 13% O ₂ : 0.3 - 0.51%	
FLUE MASS GAS FLOW : 5.3 - 6.5 g/s	
MEAN FLUE GAS TEMP : 266 - 295°C	

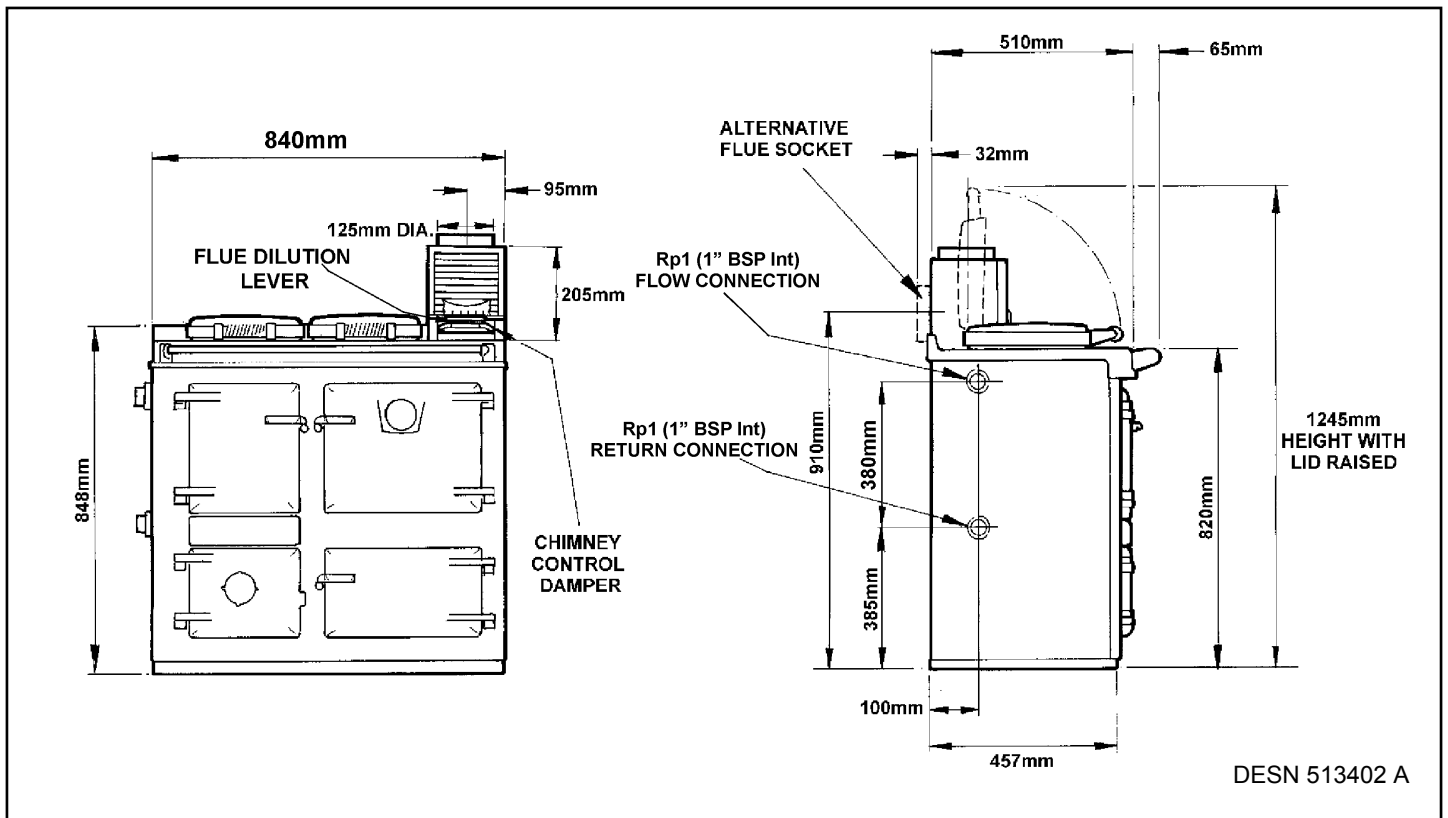

6. If burning solid fuel with 1in B.S.P., or 28mm copper flow and return pipes less than 7m each in length a towel rail/radiator with a surface area of up to 1m² should be fitted and suitably valved to close off the circulation in the event of a change to wood burning.

Domestic Hot Water and Heating (solid fuel)

When fitted for domestic hot water and heating burning solid fuel the cooker will, with a burning rate to maintain an oven temperature of 205-220°C (400-430°F), also heat 9.3m² of radiator surface and pipes.

The recommended heating surface area is based on an average heat emission of 0.5kW/m (160Btu/f h). The flow and return pipes from the cooker should be connected to a 190 litres **indirect cylinder** and the flow should be vented.

Domestic Hot Water and Heating (wood)

When fitted for domestic hot water and heating burning wood the cooker will also heat 5m² radiator surface and pipes, but increased burning rate of the fuel must be obtained to achieve this.

The recommended heating surface area is based on an average heat emission of 0.5kW/m². The flow and return pipes from the cooker should be connected to a 190 litre **indirect cylinder** and the flow be vented.

PREPARATION OF SITE

The non-combustible hearth must be solid and level and together with the walls adjacent to the cooker and chimney, conform to current Building Regulations.

The cooker and chimney flue installation should be in accordance with the relevant recommendations of BS.8303 and BS. 6461 Part 1, BS 7566 Parts 1 to 4, and the central heating system to BS. 5449 Part 1.

The boiler installation section must also be in accordance with the bylaws of the local Water Undertaking, Regulations for the Electrical Equipment of Buildings published by the Institute of Electrical Engineers and any relevant requirements of the Local Authority.

There is no requirement for an electrical power supply but ensure that any electrical wiring is correctly earthed.

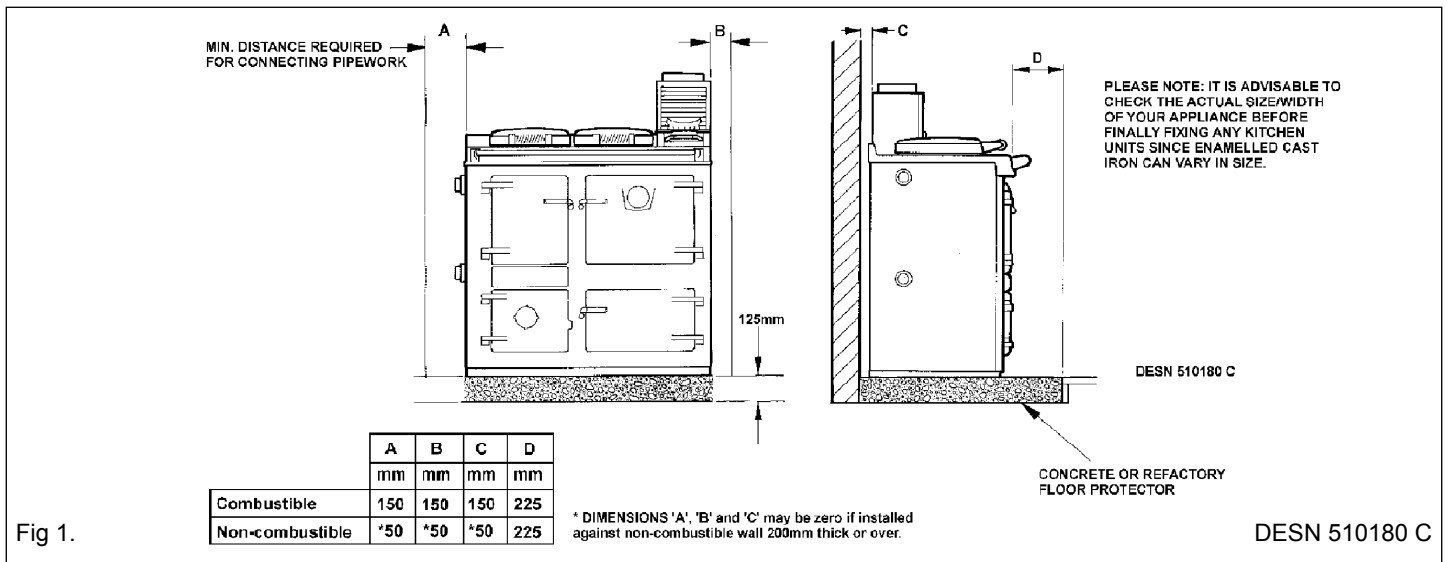

Fig 1.

COOKER POSITION

When the cooker is installed in a recess it must be 'freestanding' and not built-in solid at the sides. Ensure that any combustible material e.g. kitchen furniture is spaced away from the cooker to the recommended distances. See Fig. 1.

Tiling

Where the cooker is to stand in a recess or against a wall which is to be tiled, **in no circumstances should the tiles overlap the cooker top plate.**

THE CHIMNEY

This appliance is not suitable for installation in a shared flue system.

The minimum chimney draught requirement at nominal heat output is 12 Pascal's.

Check existing chimney

The internal and external condition of the chimney should be checked **before** the appliance is installed and rectification made where necessary to prevent leakage or porosity. The soundness of the chimney which should have a minimum flue dimension of 150mm can be confirmed by smoke testing.

Advice on the test method can be obtained from the local HETAS Ltd approved supplier.

When repairing or re-using existing chimneys it is recommended that the building control officer be consulted before the commencement of work with particular attention to the chimney height and its termination.

The chimney must be swept before installation.

Erecting New Chimney

The flue through the chimney should be formed with pre-cast moisture and acid resistant liners with a minimum internal dimension of 150mm square and all in accordance with the current Building Regulations J/1/2/3 (England and Wales) and in Scotland the Building Standard (Scotland) (Consolidation) Regulations and the Codes of Practice for Chimneys and flues BS. 6461. Part 1 and BS. 7566 Parts 1 to 4.

Ensure the chimney liners are free of projecting internal building jointing composition before the appliance is installed.

Factory made Insulating Chimneys

It is recommended the chimney be ceramic lined and comply with BS. 4543: Part 2.

The minimum diameter for a chimney is 150mm and there should not be more than two bends of 45° from vertical.

IN ALL TYPES OF CHIMNEYS THE MINIMUM HEIGHT FOR CORRECT OPERATION OF THE COOKER IS 5.5m AND SHOULD TERMINATE ABOVE THE ROOF IN ACCORDANCE WITH REGIONAL STATUTORY REQUIREMENTS. RECOMMENDED FLUE DRAUGHT - 12 PASCALS MINIMUM. THE APPLIANCE SHOULD BE INSTALLED AND CONFORM TO THE CURRENT CODES OF PRACTICE FOR INSTALLATION OF DOMESTIC HEATING AND COOKING APPLIANCES BURNING SOLID FUEL - BS. 8303.

ALWAYS ADVISE THE USER TO CLEAN THE COOKER FLUES IN ACCORDANCE WITH THE OPERATING INSTRUCTIONS AND TO HAVE THE CHIMNEY SWEEPED AT A MINIMUM OF 12 MONTHLY INTERVALS AFTER THE COOKER IS COMMISSIONED.

Cooker Flue Connection

The position of available type of flue layouts are shown in Figs. 2, 3 and 4, the cooker flue chamber is adaptable to provide either top or back flue outlets, by means of the reversible loose socket.

(a) Rear Flue Outlet

This must only be used where there is a brick flue immediately behind the cooker. Provision must be made for a condensate collecting vessel and cleaning door. See Fig. 3.

NOTE: EXTENDED HORIZONTAL FLUE PIPE CONNECTION IS ALLOWED UP TO A MAXIMUM OF 150mm IN LENGTH. NO BEND CONNECTIONS ARE ALLOWED. WHEN BURNING BITUMINOUS COAL, BACK OUTLETS SHOULD NOT BE USED.

(b) Top Flue Outlet

The cooker should be connected to the main flue via a 125mm minimum diameter cast iron pipe or appropriately internally/externally vitreous enamelled mild steel pipe and be sealed to the cooker flue chamber with soft rope and fire cement.

Any bends in the flue pipe must not be less than 135° (45° from horizontal) and be complete with a cleaning door.

Flue Layouts

In Fig. 2 the cooker is installed in an existing recess. There must be a clearance of not less than 150mm between the top of the flue pipe and any overhanging brickwork.

Any cavities or pockets above the register plate should as far as possible be filled and if necessary the flue pipe should be extended into the throat of the chimney and soot door provided for chimney sweeping.

If a flue liner or insulated chimney is used, the size should not be less than 150mm.

In Fig. 3 the cooker is connected direct to a brick flue. Horizontal pipe runs between cooker and brick flue must not be used.

In Fig. 4 the cooker is connected to an existing brick flue with a length of flue pipe. Square bends and horizontal runs must not be used. There must be a cleaning door at every bend.

NOTE: WHATEVER METHOD OF INSTALLATION IS EMPLOYED, AIR MUST NOT BE ALLOWED TO ENTER THE CHIMNEY EXCEPT THROUGH THE COOKER. ALL JOINTS MUST BE AIRTIGHT.

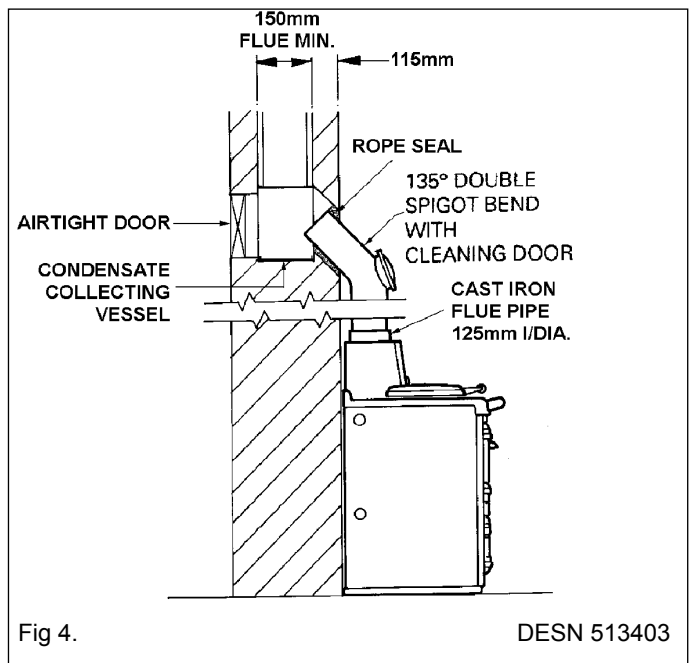
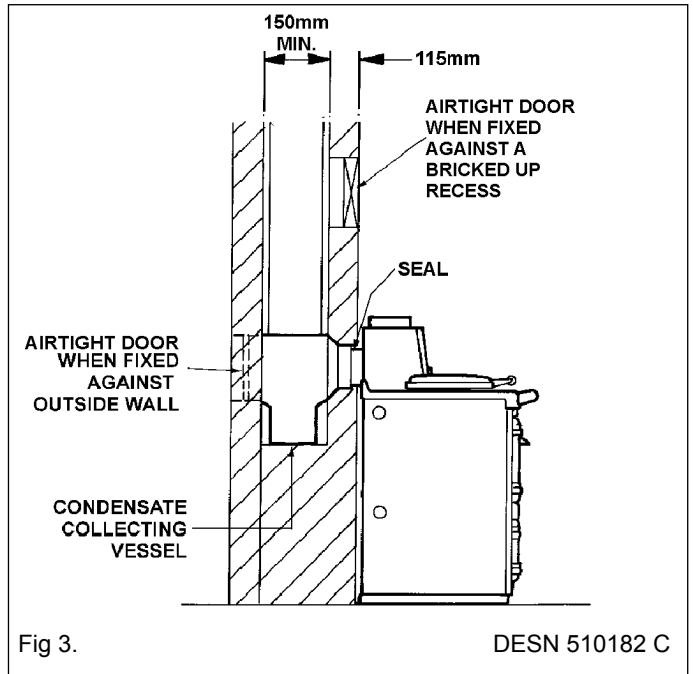
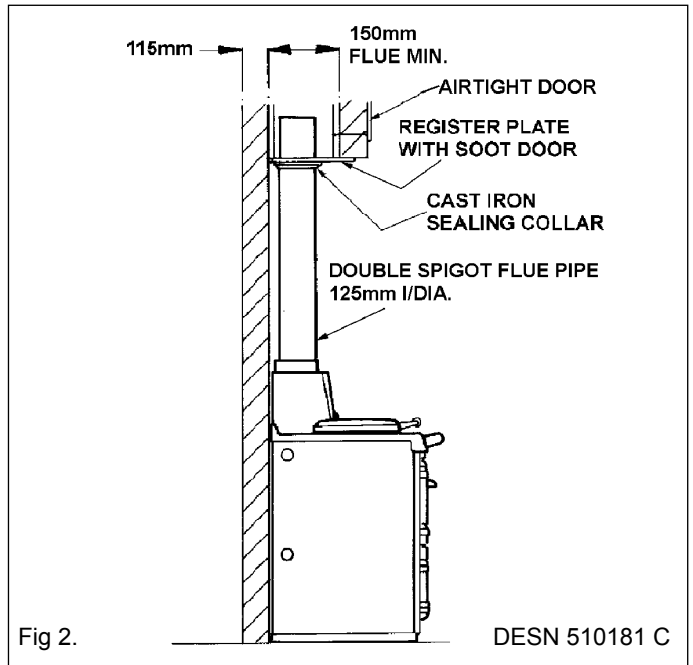

If the chimney is unlined, and there is any doubt about its condition, it should be lined in accordance with Building Regulations J/1/2/3.

PROVISION MUST ALWAYS BE MADE FOR SWEEPING THE CHIMNEY.

IMPORTANT: CEMENT TYPE PIPES AND FITTINGS MUST NOT BE USED WITHIN 2m OF THE COOKER. CHIMNEYS OF PLAIN PIPE ARE NOT RECOMMENDED BUT CERTAIN PROPRIETARY MAKES OF INSULATED CHIMNEY ARE SUITABLE.

AIR SUPPLY

Provision must be made for additional ventilation. A permanent unobstructed air vent having a minimum effective area of 22cm² must communicate to outside air or an adjacent room which in turn has a permanent vent of at least the same size to outside air.

If a flue draught stabiliser is fitted in the flue this vent size must be increased to a minimum 49cm². If this appliance is used with an additional appliance of a similar type then the air supply must be adequate for both appliances in accordance with Building Regulations.

Any air inlet grilles must be positioned so that they are not liable to blockage.

Effect of Extractor Fan

It is not permissible to use an air extraction device in the same room as the appliance unless ventilation is provided to prevent any adverse effect on the flue.

CENTRAL HEATING AND HOT WATER SYSTEM

The maximum water pressure is 1.75 bar.

The water capacity of the boiler is 12 litres.

It is recommended that a 190 litre indirect hot water storage cylinder of the double feed type e.g. (Manufactured by Albion Cylinders), complying with BS.1566 Part 1: DF Type 10 should be lagged and fixed vertically as near as possible to the cooker. The 28mm minimum diameter primary flow and return pipes must not exceed 10m in length and pipes longer than 5m must be lagged.

Ensure that the flow pipe has an open vent and rises continuously from the boiler to the cylinder to ensure good gravity circulation.

In combined systems, the water draw-off pipes to the taps must be dead-leg connection from the vent/expansion pipe. There are only two boiler tappings on this cooker and a typical design layout is shown in Fig. 5.

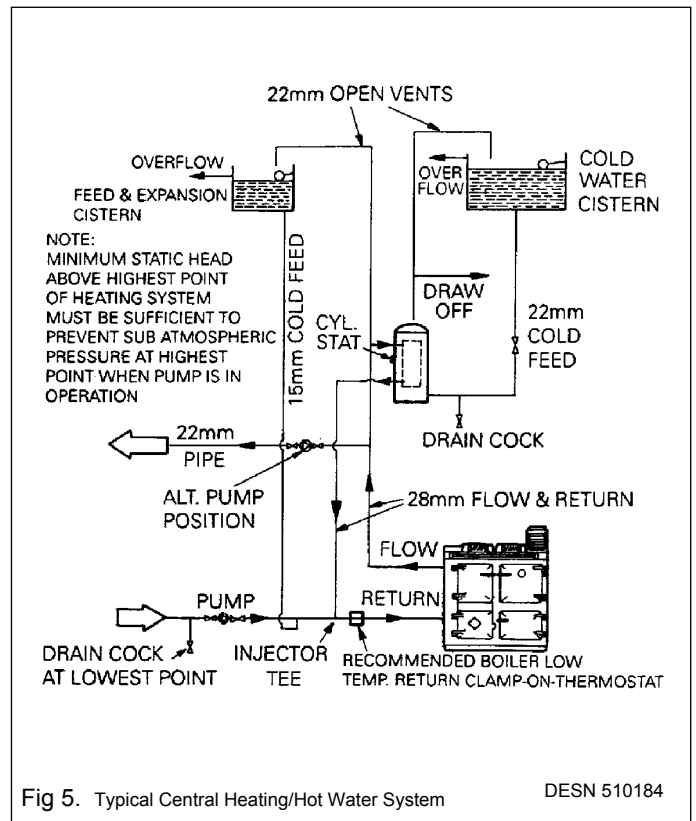

Fig 5. Typical Central Heating/Hot Water System DESN 510184

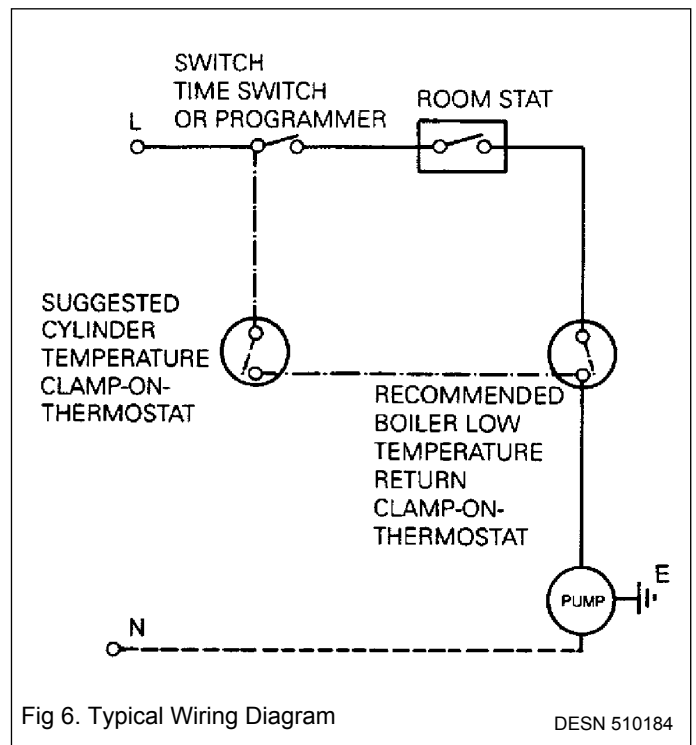

Fig 6. Typical Wiring Diagram DESN 510184

An injector tee is provided which must be fitted to ensure adequate primary flow circulation when the water circulator is operating, otherwise there may be a lack of domestic hot water. The heating flow and return pipes may be 22mm, the return pipe being connected to the 28mm primary return by the injector tee, and the tee output connected to the boiler return pipe.

All installations must be fitted with a drain tap at the lowest point of the system.

NOTE: In some circumstances it may be possible to overheat the appliance and the water inside will boil. This will be evident by the sound of a knocking noise coming from the appliance and pipes around the house. If this occurs, close off all air controls and manually start the central heating pump if fitted. Opening the oven doors and hotplate covers will help to release heat from the appliance. Be aware that steam and boiling water will be expended from any open vent from the heating system probably in the roof space at the expansion tank.

Boiler - Recommendations

Water circulators which are continually operative will in conjunction with prolonged burning under banked conditions create cool boiler surfaces within the firebox.

This in turn will encourage boiler surface condensation followed by surface oxidisation and reduced life span of the boiler.

To minimise this incident we strongly recommend a water pipe clamp on thermostat e.g. EBERLE Type 8750 or SATCHWELL SUNVIC Type PA fitted to the heating return pipe and sited between the injector tee and the cooker as shown on Fig. 5 -

Typical Central Heating Hot Water System.

The thermostat should be electrically connected to the water circulator as indicated on the 'Typical Wiring Diagram' Fig. 6 and the adjustable dial should be set at a temperature of 50°C (122°F). A fall in the return pipe water temperature below 50°C interrupts the power to the water circulator which will then not operate until the temperature exceeds 50°C and power is restored.

FAILURE TO CONFORM TO THIS RECOMMENDATION MAY RESULT IN PREMATURE FAILURE OF THE BOILER.

HIGH UPDRAUGHTS

Tall chimneys may develop excessively high updraughts which prevent the appliance operating correctly.

It is recommended that a proprietary brand adjustable flue draught stabiliser having an operable cross sectional area of 126cm² be fitted above the flue pipe connection, either in the brickwork or into a right-angle 'T' fitting in the flue pipe position that will not inconvenience appliance operation or maintenance.

The flue dilution lever may be used to combat temporary high updraughts such as high winds but is not intended to replace a draught stabiliser.

INSTALLATION

Place the cooker in the intended position and lift out the surface ground hotplate, checking that the joint between the underside of the hob and the top of the cooker are intact.

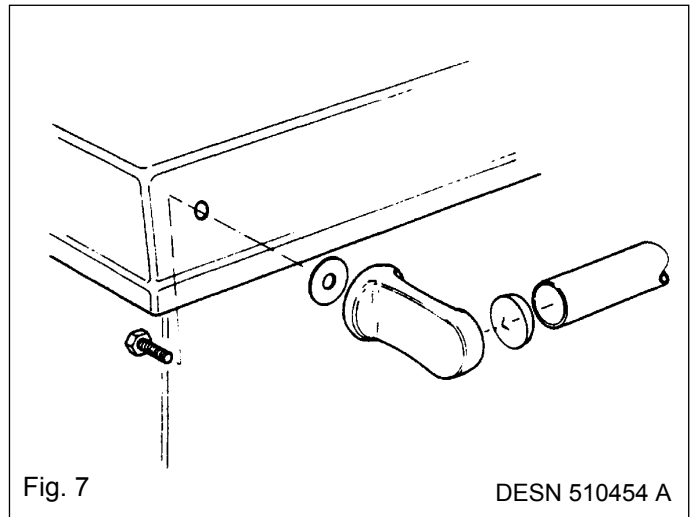

Any joints which have opened should be made good with fire cement provided.

If the appliance is installed near combustible material then as well as adhering to minimum clearances in Fig. 1 additional non-combustible insulation must be fitted to the wall to protect the area around the flue and fluebox. The insulation must reach a minimum distance of 150mm either side of the flue/flue box and follow the line of the flue. The minimum specification for this material is Superwool 607 LTI with a density of 320kg/m³, a thickness of 10mm and a self finish. There must be a minimum 16mm air gap between the insulation board and an adjacent combustible wall surface. A higher specification material may be used but the air gap must be maintained.

Replace the hotplate making sure that it is seating evenly on the soft rope seal and that it is approximately 1.5mm proud of the enamelled top plate, with an equal space all round.

Connect pipework to boiler flow and return tappings.

Fit the flue chamber which should be given a 1mm smear of fire cement on the underside then screwed to the cooker. Make sure there is a good seal between the flue chamber and the cooker top (if there is an ingress of air it can affect the flue draught and proper working of the cooker). Before the fire cement hardens remove any surplus with a damp cloth then polish with a dry cloth.

Open the firebox and ashpit doors and check that the bottomgrate is in position. Operate the riddling lever to ensure the bottomgrate operation.

Failure to do so can result in the enamel surface being permanently marked.

The handrail brackets are held on the front end of the cooker top-plate casting. Remove the travel nuts and replace with the handrail brackets ensuring the fibre protecting washers are in position. Insert the handrail with fitted endcaps into the brackets, positioning them correctly and tighten the locating bolts. (Fig. 7).

TESTING AND COMMISSIONING

After completing the installation, the Heating Contractor should demonstrate to the user, the operation of the appliance and the routine flue cleaning method.

- (i) Check that the system is full of water and free from air locks.
- (ii) When lighting pull the flue chamber damper open to maximum.
- (iii) Add paper and sticks with a small quantity of fuel through fuelling aperture onto bottomgrate and close the firebox door.
- (iv) Open ashpit door, ignite fuel; and close the ashpit door when fuel is well alight with spinwheel on ashpit door at required setting.
- (v) Allow the cooker to heat up gradually at first time lighting.

NOTE: SMOKE/SMELL EMITTED DURING INITIAL USAGE

Some parts of the cooker have been coated with a light covering of protective oil. During initial operation of the cooker, this may cause smoke/smell to be emitted and is normal and not a fault with the appliance. It is therefore advisable to open doors and or windows to allow for ventilation.

Lift the lids to prevent staining the linings.

**LEAVE INSTRUCTIONS FOR
FUTURE USE**

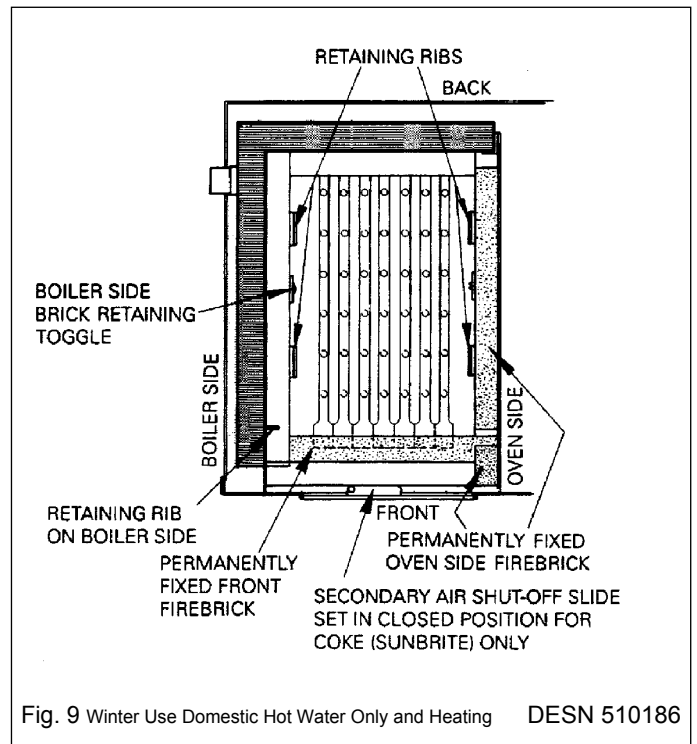
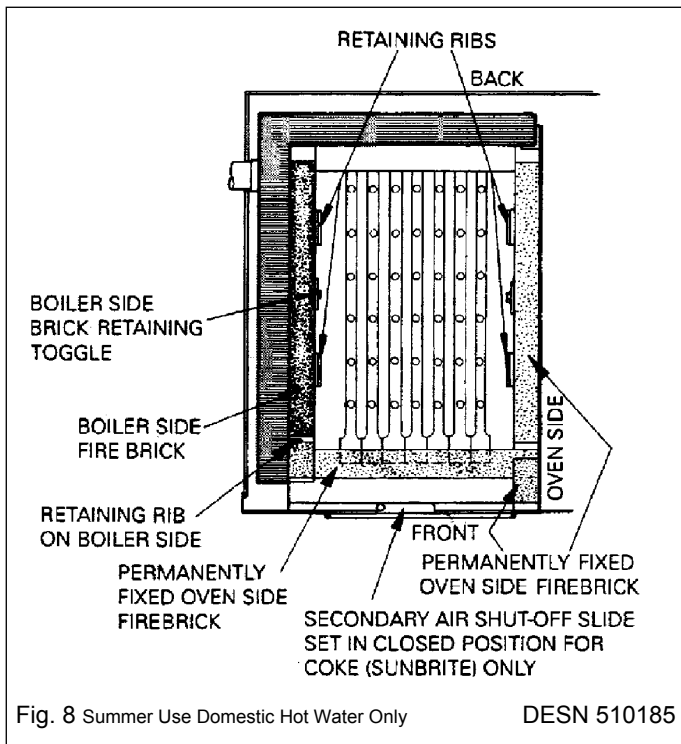

GENERAL - FIREBRICK POSITIONS AND REPLACEMENT

location determines the amount of hot water supplied in winter and summer seasons.

The oven side and firebox front firebricks are permanently fixed with fire cement, whilst the two boiler face side bricks are located for the summer season thereby providing domestic hot water only. For winter use or central heating facilities, the boiler face side bricks are removed. See Fig. 8, 9 + 10. The firebricks fitted to Rayburn Cookers are of first quality manufacture and providing the cooker has been installed and used correctly will have a reasonable life. There are, however, expendable items and in time will require renewal. The renewal of firebricks is not major operation and can be carried out by the average person. The boiler side firebricks are supported on a frame on the boiler sides and are held in position by a retaining toggle at the top.

The front plate protection firebrick is held in position by a retaining rib on the boiler side. The firebricks are not sealed in with fire cement and can be removed and refitted quite simply. See Fig. 10.

Replacement bricks either in sets or singly can be obtained from your Rayburn Stockist. Quote the serial number which will be found on a brass plate inside the roasting oven.

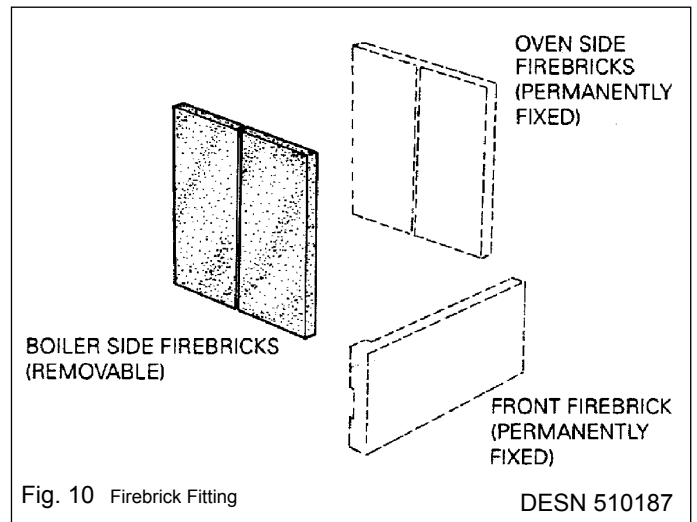

For further advice or information contact your
local distributor/stockist

With AGA Rangemaster's policy of continuous
product improvement, the Company reserves
the right to change specifications and make
modifications to the appliance described at any
time.



Made by The text "Made by" followed by the AGA logo, which is a small black oval containing the letters "AGA" in white.

Manufactured by
AGA Rangemaster
Station Road
Ketley Telford
Shropshire TF1 5AQ
England

www.rayburn.co.uk
www.agacookshop.co.uk